



# Design for Hot Dip Galvanizing

(For convenience purposes the content of this chapter is also available on a wall chart)

## 9.1 INTRODUCTION

When designing a structure which is to be hot dip galvanized, it must be borne in mind that articles are immersed into and withdrawn from a bath of molten zinc heated to a temperature of 450°C. Design and fabrication is required to conform to acceptable standards which apply, regardless of whether a galvanized or a painted coating is to be applied. In the case of hot dip galvanizing, some additional requirements which aid access and drainage of molten zinc, will improve the quality of the coating and also reduce costs.

With certain fabrications, holes which are present for other purposes may fulfil the requirements of venting of air and draining of zinc; in other cases it may be necessary to provide extra holes for this purpose.

For complete protection, molten zinc must be able to flow freely to all parts of the surfaces of a fabrication. With hollow sections or where there are internal compartments, the galvanizing of the internal surfaces eliminates any danger of hidden corrosion occurring in service.

In addition to using the correct specifications in terms of coating requirements, the steel chemistry should be of a quality suitable for galvanizing (Chapter 7).

### Some general principles for guidance are:

- Holes both for venting and draining should be as large as possible. The absolute minimum hole sizes are given in table 17.
- Holes for venting and draining should be diagonally opposite one another at the high point and low point of the fabrication as it is suspended for galvanizing (figure 43).
- With hollow sections sealed at the ends, holes should be provided, again diagonally opposite one another, as near as possible to the ends of the hollow member (figure 44). In some cases it may be more economical to provide "V" or "U" shaped notches (figure 45)

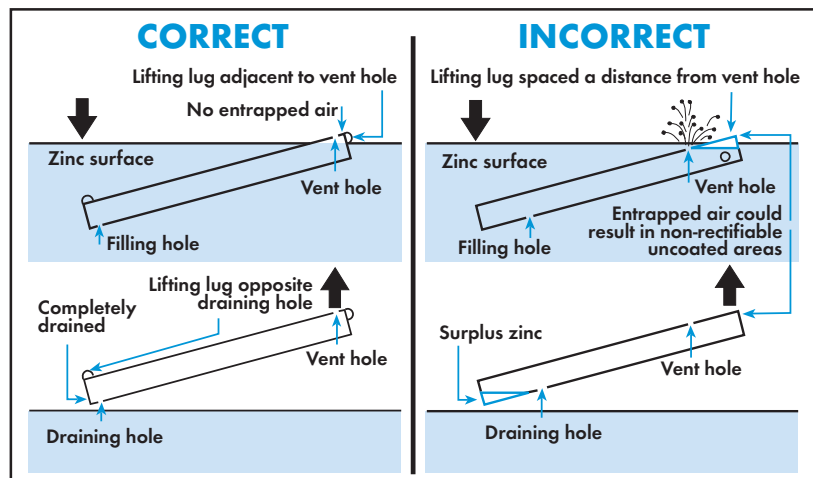

Figure 43.

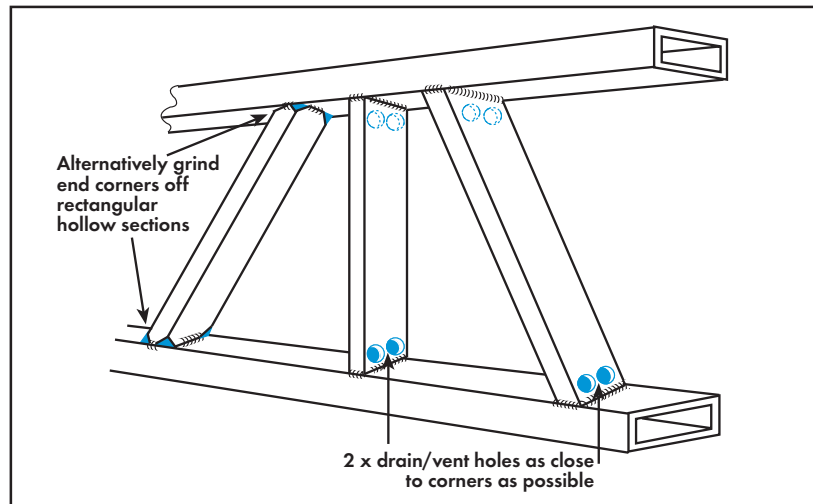

Figure 44.

in the ends of the tubes, or to grind corners off rectangular hollow sections. These procedures will provide ideal means for venting and draining.

- Where holes are provided in end plates or capping pieces, they should be placed diagonally opposite to one another, off centre and as near as possible to the wall of the member to which the end plate is connected (figure 46).
- Internal and external stiffeners, baffles, diaphragms, gussets etc., should have the corners cropped and angle bracings should if possible be stopped short of the main boom flange to aid the flow of molten zinc and to prevent air

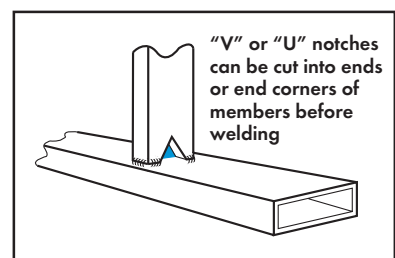

Figure 45.

entrapment (figures 49, 50, 51 and 52).

- Bolted joints are best made after hot dip galvanizing.

### Size

Facilities exist to hot dip galvanize articles of virtually any size and shape.

GUIDELINES FOR MINIMUM VENT FILL AND DRAINAGE HOLE SIZES - REQUIRED BY SECTION LENGTH											
Tube Dia	≤ 50	60 - 76	89	102 - 114	127 - 152	165	219	245	273	324	355
RHS Sizes (mm)	50 x 30	80 x 40	80 x 80	90 x 90	160 x 80	200 x 100	180 x 180	200 x 200	300 x 200	400 x 200	300 x 300
	60 x 40	70 x 70	120 x 60	120 x 80	120 x 120	150 x 150	250 x 150	220 x 220	250 x 250		450 x 250
	50 x 50	100 x 50		100 x 100	150 x 100				340 x 200		
	60 x 60	76 x 76			140 x 140						
Length (m)	Hole size (mm)										
1	10 (12)	10 (12)	10 (12)	12 (2x10)	16 (2x12)	20 (2x16)	25 (2x20)	30 (2x25)	30 (2x25)	40 (2x30)	40 (2x30)
2	10 (12)	10 (12)	12 (2x10)	12 (2x10)	16 (2x12)	20 (2x16)	25 (2x20)	30 (2x25)	30 (2x25)	40 (2x30)	50 (2x40)
3	10 (12)	12 (2x10)	12 (2x10)	12 (2x10)	16 (2x12)	20 (2x16)	25 (2x20)	30 (2x25)	40 (2x30)	50 (2x40)	50 (2x40)
4	12 (2x10)	12 (2x10)	16 (2x12)	16 (2x12)	16 (2x12)	25 (2x20)	25 (2x20)	30 (2x25)	40 (2x30)	50 (2x40)	2x50 (3x40)
5	12 (2x10)	16 (2x12)	16 (2x12)	16 (2x12)	25 (2x20)	25 (2x20)	30 (2x25)	30 (2x25)	50 (2x40)	50 (2x40)	2x50 (3x40)
6	12 (2x10)	16 (2x12)	20 (2x16)	20 (2x16)	25 (2x20)	25 (2x20)	50 (2x30)	50 (2x40)	50 (2x40)	2x50 (3x40)	2x50 (3x40)
7	16 (2x12)	16 (2x12)	20 (2x16)	20 (2x16)	25 (2x20)	25 (2x20)	50 (2x30)	50 (2x40)	50 (2x40)	2x50 (3x40)	2x50 (3x40)
8	16 (2x12)	16 (2x12)	20 (2x16)	25 (2x20)	25 (2x20)	2x25 (3x20)	50 (2x30)	50 (2x40)	2x50 (3x40)	2x50 (3x40)	2x50 (3x40)
9	16 (2x12)	16 (2x12)	25 (2x20)	25 (2x20)	2x25 (3x20)	2x25 (3x20)	50 (2x30)	2x50 (3x40)	2x50 (3x40)	2x50 (3x40)	2x50 (3x40)
10+	20 (2x16)	25 (2x16)	25 (2x20)	25 (2x20)	2x25 (3x20)	2x25 (3x20)	50 (2x30)	2x50 (3x40)	2x50 (3x40)	2x50 (3x40)	2x50 (3x40)

Note: The hole sizes specified above may be substituted with a larger number of smaller holes. (minimum ø 10mm for vent and ø 12mm for fill/drain hole)

Table 17.

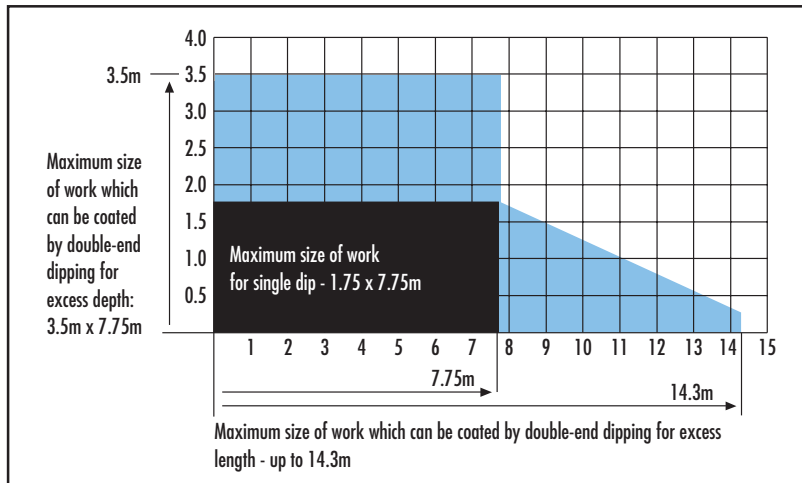

Table 18. Schematic indication of double-end dipping capacity of a galvanizing bath 8 metres long x 2 metres deep.

(See list of members with bath sizes - refer to the current copy of Hot Dip Galvanizing Today – the Association Journal. When an article is too big for single immersion in the largest bath available it may be possible to galvanize it by double-end dipping (figure 47 and table 18), depending on the handling facilities and layout of the galvanizing plant (check with the galvanizer). Note: The cost of double end dipping can be higher than the standard cost of hot dip galvanizing. Large

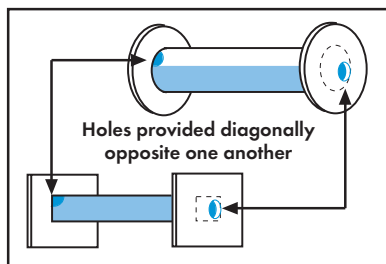

Figure 46.

cylindrical objects can often be galvanized by progressive immersion (figure 48).

#### Modular Design

Large structures are also hot dip galvanized by designing in modules for later assembly by bolting or welding. Modular design techniques often produce economics in manufacture and assembly through simplified handling and transport.

#### Steel Grade

It is possible to hot dip galvanize all structural steels and the ultimate coating thickness achieved is determined by steel analysis, immersion time and to a lesser degree, zinc temperature. It is for this reason that hot dip galvanizing specifications provide for minimum coating thickness and no maximum limit is set (see NOTE 1 in Chapter 10). Reactive levels of silicon in steel and excessively high phos-

phorus even at relatively low silicon levels can result in thicker coatings. Thicker coatings provide extended corrosion protection but can occasionally be prone to brittleness. The resultant coating could be aesthetically less pleasing sometimes displaying dull grey to black surface patches. (Chapter 7).

#### Fabrication

##### Bending

Steels that are susceptible to embrittlement and fatigue failure should be bent over a smooth mandrel with a minimum radius 2 to 3 times material thickness. Where possible hot work at red heat. Cold bending is unlikely to affect steels less than 3mm thick.

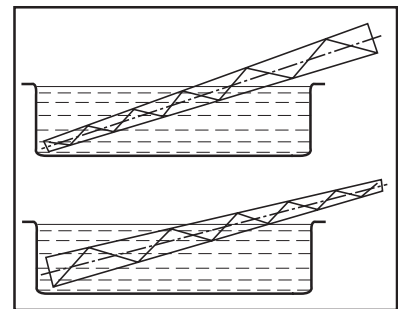

Figure 47.

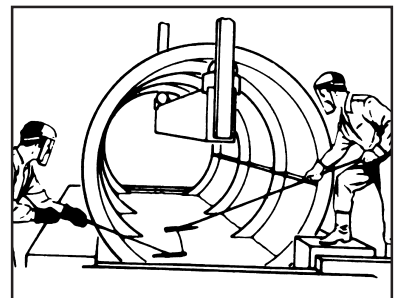

Figure 48. Progressive dipping.

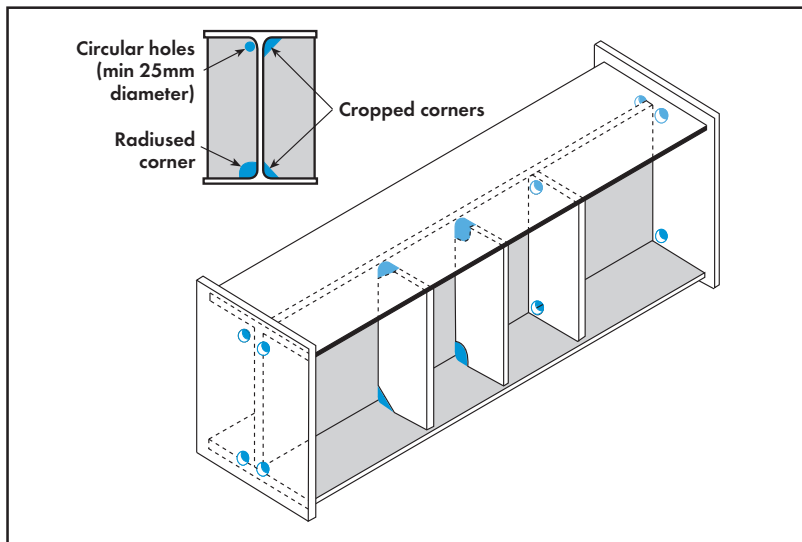

Figure 49.

Before bending, edges should be radiused over the full arc of the bend.

### Bending and Forming After Hot Dip Galvanizing

Components which have been hot dip galvanized should not be bent or formed by applying heat above the melting temperature of zinc as this can cause embrittlement due to intergranular liquid zinc penetration between steel crystal boundaries.

### Burrs

Unlike a paint coating, burrs will be over-coated by hot dip galvanizing but the removal of a burr after galvanizing may result in the presence of a small uncoated surface and for this reason, burrs must be removed prior to galvanizing.

### Edges

Because a hot dip galvanized coating is formed by metallurgical reaction between molten zinc and steel, the coating thickness on edges and corners is thicker than that on flat surfaces. Thus the rounding of sharp edges, as required for paint coatings, is not necessary. If subsequent painting is required, sharp edges should be rounded during fabrication to a radius of 3mm or 50% of steel thickness.

**Edge Distances.** In accordance with SANS 10162 Clause 22.3.2, which defines edge distance as “the minimum distance from the centre of a bolt to any edge shall be in accordance with table 8”.

**Punching.** Full size punching of holes is permitted when (amongst other requirements such as distortion free, burr free, not subject to fatigue), according to Clause 4.3.6.3.c of SANS 2001-CS1, “the thickness of the material is not greater than the hole diameter plus 3mm; nor greater than 12mm”.

Clause 4.3.6.4 Punching and reaming eads: “Punching is permitted without the conditions of 4.3.6.3 provided the holes are punched at least 2mm less in diameter than the required size and the hole is subsequently reamed to the full diameter.”

Material of any thickness may be punched at least 3mm undersize and then reamed, or be drilled. Good shop practice in relation to ratios of punched hole diameter to plate thickness, and punch/die diametral clearance to plate thickness should be observed.

For static loading, holes may be punched full size in material up to  $\frac{4500}{F_y}$  mm thick where  $F_y$  is material yield stress up to 360MPa.

### Shearing and Flame Cutting

Edges of steel sections greater than 16mm thick subject to tensile loads should be machined or machine flame cut. Edges of sections up to 16mm thick may be cut by shearing.

Sheared edges to be bent during fabrication should have stress raising features such as burrs and flame gouges removed to a depth of at least 1.5mm.

Temperatures associated with flame cutting alter the surface properties of steel and if such surfaces are not thoroughly ground, a thinner galvanized coating will be formed (usually below the specified minimum).

### Welding and Weld Slag

Welds should be continuous and free from excessive pin-holing and porosity. Weld slag, normally associated with stick welding, is not readily removed by acid cleaning and such slag must be

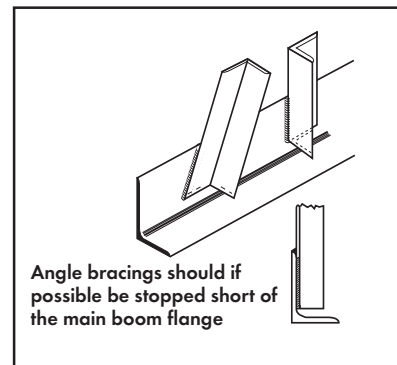

Figure 50.

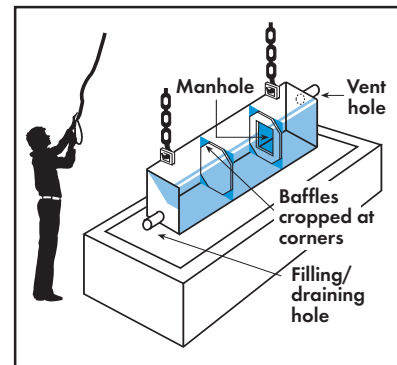

Figure 51.

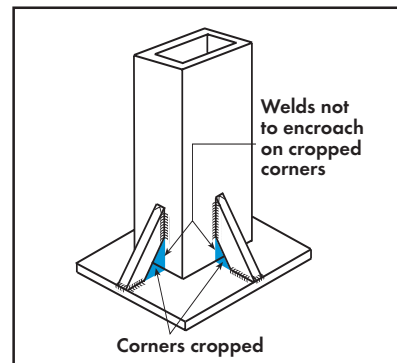

Figure 52.

removed by abrasive blast cleaning, chipping, grinding, flame cleaning or a pneumatic needle gun, prior to hot dip galvanizing. Shielded arc welding is preferred since this method does not result in the presence of tightly adhering slag (figure 53 and Chapter 14).

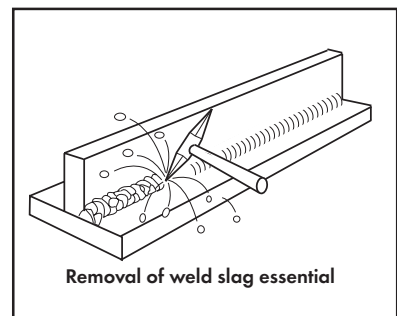

Figure 53.

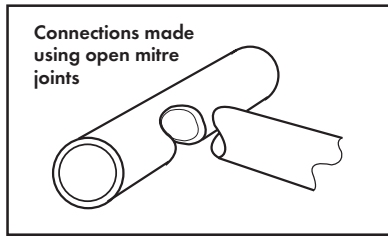

Figure 54.

In case of double-sided fillet welds, the weld must be continued around the ends to prevent unnecessary penetration of acid into any crevices (figure 61).

### Weld Spatter

Weld spatter does not reduce the protective properties of a hot dip galvanized coating to the same extent as with a paint coating, but it is recommended practice to remove spatter prior to hot dip galvanizing.

## 9.2 VENTING, FILLING AND DRAINAGE

External stiffeners, welded gussets and webs on columns and beams and gussets in channel sections should have cropped corners. The gaps created should be as large as possible without compromising structural strength. If welding is required around the edge created, a radiused corner is desirable to facilitate continuity of the weld around the cut end to the other side. Circular holes are less effective: if used, they should be as close to corners and edges as practical. Where more convenient, the cropped corners or holes may be in the main beam. Consultation with the galvanizer, regarding the appropriate vent and drainage hole sizes is recommended (figure 49 and table 17).

### Welded Pipe Sections

Closed sections must never be incorporated in a fabrication. Sections should be interconnected using open mitred joints as illustrated in figure 54, or interconnecting holes should be drilled before fabrication as in figure 55.

Alternatively external holes may be positioned as in figure 56, a method which is often preferred by the galvanizer, since quick visual inspection shows that the work is safe to hot dip galvanize.

Pipe ends can be left open, or provided with removable plugs. (See unwanted vent holes).

### Unwanted Vent Holes

These may be closed by hammering in lead or aluminium plugs after galva-

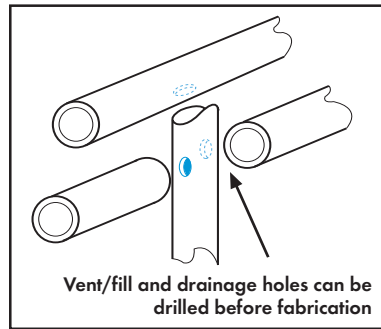

Figure 55.

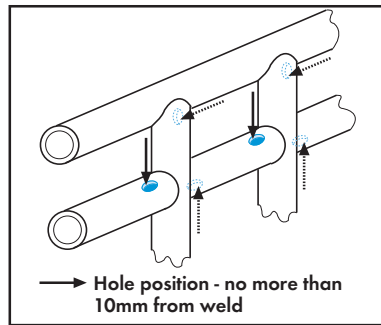

Figure 56.

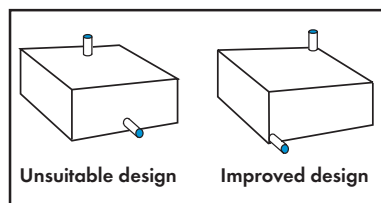

Figure 57.

nizing and filing off flush with surrounding surfaces.

### Small Tubular Fabrications

Small tubular fabrications must be vented, preferably with holes not less than 10mm diameter (table 17).

### Tubular Fabrications / Hollow Structurals

Drain/vent hole sizes should preferably be 25% of internal diameter or diagonal dimension for components with a maximum cross sectional area of 180cm<sup>2</sup>. This percentage can be influenced by the shape of the fabrication. Consultation with the galvanizer at the design stage is recommended.

### Tubular Fabrication After Hot Dip Galvanizing

The requirement for bending tubes after hot dip galvanizing, ie. for the fabrication of gates etc. must be carried out according to the method set out in the Bend Test (galvanized tube). See 11.5 Adhesion of the Coating, page 35.

### Tanks and Closed Vessels

When both internal and external surfaces are to be hot dip galvanized at

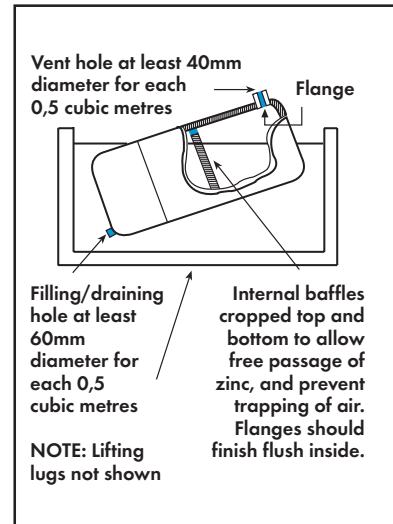

Figure 58.

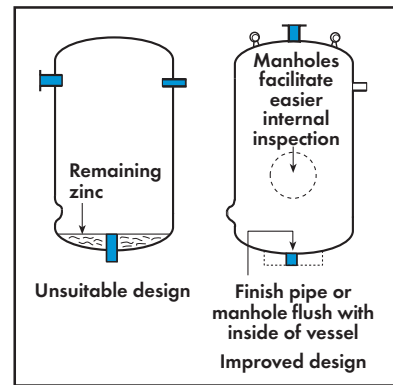

Figure 59.

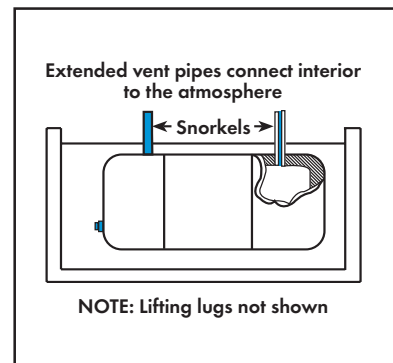

Figure 60.

least one filling and draining hole must be provided, with a vent hole diagonally opposite to allow the exit of air during immersion (figure 57). For each 0,5 cubic metres of volume, provide at least one fill/drain hole of minimum size  $\phi 60\text{mm}$  and vent hole of minimum size  $\phi 40\text{mm}$  or both at  $\phi 60\text{mm}$  (figure 58).

Internal baffles should be cropped as illustrated (figure 51 and 58). Manholes or pipes should finish flush inside to prevent trapping excess zinc (figure 59).

Lifting lugs should be provided opposite the biggest and most accessible filling / draining holes and adjacent to the vent hole on the opposite end (figure 43). The lugs must be designed to accommodate the excess mass of molten zinc within the cylinder / pipe on withdrawal.

Large vessels require an appropriate size manhole in the baffle.

When vessels and heat exchangers etc., are not to be galvanized internally, 'snorkels' or extended vent pipes must be fitted to allow air or steam to exit above the level of molten zinc in the galvanizing bath (figure 60).

### 9.3 MASKING, WELDING, HANDLING, MINIMIZING DISTORTION, CLEARANCE FOR MOVING PARTS AND IDENTIFICATION

#### Masking

Masking materials have been developed, which if applied prior to hot dip galvanizing, will prevent the formation of the galvanized coating on surfaces where it is not required.

#### Combinations of Ferrous Surfaces

Fabrications containing a combination of castings and steels, or rusted and mill scaled surfaces must be abrasive blast cleaned before hot dip galvanizing.

#### Provision for Handling

Work not suitable for handling with chains, baskets, hooks or jigs must be provided with suspension holes or lifting lugs (figure 43). If in doubt, consult the galvanizer.

#### Materials Suitable for Hot Dip Galvanizing

All ferrous materials are suitable, including sound stress-free castings.

Brazed assemblies may be hot dip galvanized but first consult the galvanizer. Assemblies soft soldered or aluminium rivetted cannot be hot dip galvanized.

#### Distortion

Distortion can be minimised by:

- Use of symmetrical designs (figure 62).
- Use of sections of a similar thickness (figure 63).
- Use of stiffened sections, particularly when steel is unsupported and of less than 3 - 4mm thick (figure 64).
- Use of preformed members with

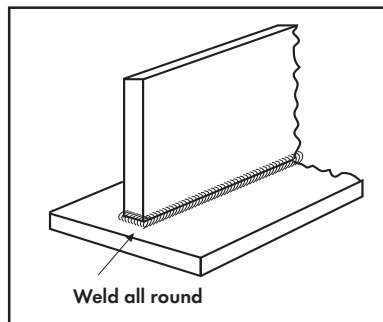

Figure 61.

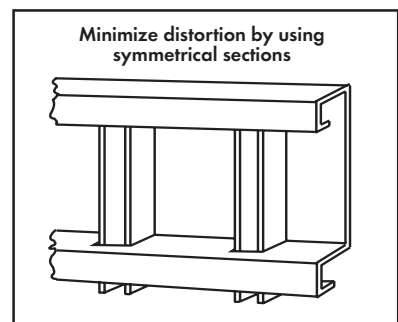

Figure 62.

the correct minimum bend radius to minimise stress.

- Use of balanced or sequence welding techniques to minimise stresses.
- Large open fabrications, thin walled trough sections and rectangular tanks may require temporary cross stays to prevent distortion during hot dip galvanizing.
- Maximise fill, drain and vent hole sizes and optimize their relative positions.
- Complete and rapid immersion of the item in the galvanizing bath i.e. avoid double end dipping if possible.
- Air cooling after hot dip galvanizing in preference to water quenching.

Use of symmetrical sections minimises distortion during hot dip galvanizing. Avoid combinations of thick and thin material. Bolted connections are rec-

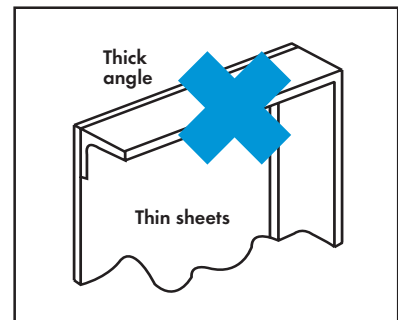

Figure 63.

ommended for assembly after hot dip galvanizing.

#### Overlapping Surfaces

A minimum gap of at least 2mm between overlapping surfaces and back-to-back angles and channels, must be provided (figures 65, 66 and 67).

When small overlaps are unavoidable, seal edges by welding.

In circumstances where seal welding is not practical, a degree of temporary

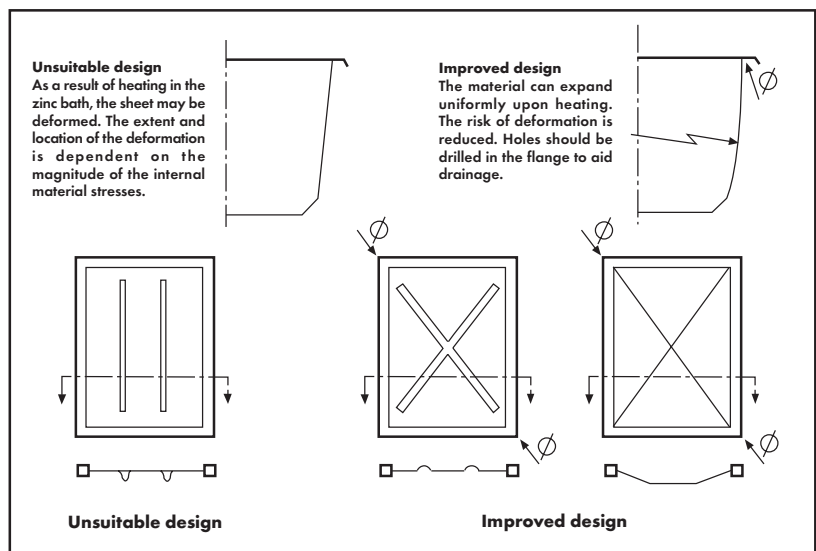

Figure 64.

surface staining at crevices may be apparent after hot dip galvanizing and quenching. This is often incorrectly described as acid staining. Clean with a bristle brush and mild detergent if necessary. If necessary crevices of this nature can be sealed after hot dip galvanizing with an appropriate sealant.

### Larger Overlapping Surfaces

If contacting surfaces cannot be avoided, one 10mm diameter hole should be provided in one of the members for every 100cm<sup>2</sup> of overlap surface. The perimeter of the contacting surface can

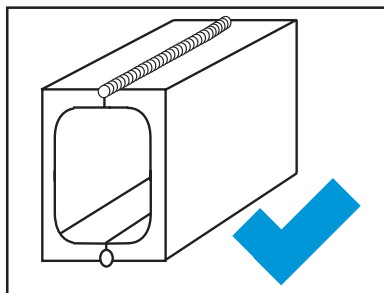

Figure 65.

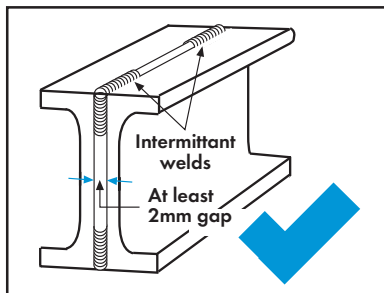

Figure 66.

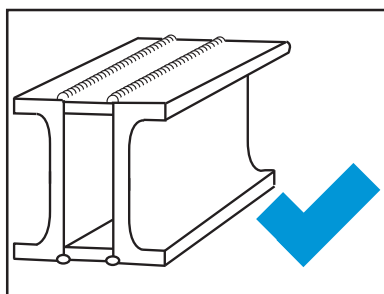

Figure 67.

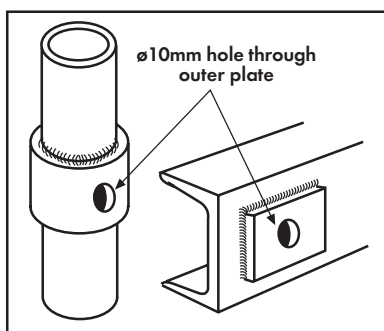

Figure 68.

be continuously welded. This requirement is of particular importance when using thin sections. Vent hole sizes for thicker steels >10mm thick and overlap areas > 300cm<sup>2</sup> should be agreed upon by the galvanizer prior to fabrication (figures 68 and 69). A vent hole in one member will ensure the safety of galvanizing personnel and prevent damage to the article. Alternatively provide at least a 2mm gap between members.

### Strengthening Gussets and Webs

Welded strengthening gussets and webs on columns and beams, and strengthening gussets in members fabricated from channel or I-beam sections should have corners cropped or holed (figures 49 & 52),

- to prevent the entrapment of air in pockets and corners allowing complete access of pickle acids and molten zinc to the entire surface of the product, and
- to facilitate drainage during withdrawal from degreaser, acid solutions, rinse-water, flux and molten zinc.

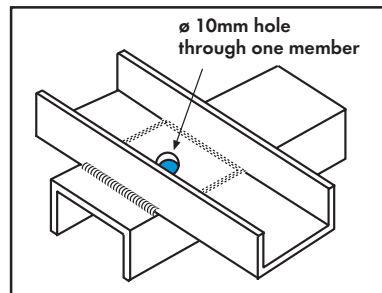

Figure 69.

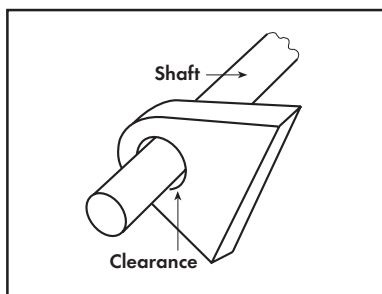

Figure 70.

### Clearance for Moving Parts

Drop handles, hinges, shackles, shafts and spindles require a radial clearance, to allow for the thickness of the hot dip galvanized coating (figure 70).

### Identification Markings

For permanent identification use heavily embossed, punched or welded lettering (figure 71). For temporary identification use heavily embossed metal tags wired to the work, water soluble

paint or an appropriate marking pen.

Do not use paints, adhesive labels or any other product that cannot be readily removed by degreasing or pickling (figure 72). If present, these coatings require to be removed by paint stripper or abrasive blasting prior to pickling and hot dip galvanizing.

### Hot Dip Galvanized Fasteners

Hot dip galvanized fasteners are recommended for use with hot dip galvanized or painted structures, but if SANS 121/ISO 1461 is not specified, there is every likelihood that thinner zinc or cadmium electro plated coatings will be supplied. (Chapter 13).

## 9.4 PREVENTING DISTORTION

### Products Shaped by Bending

Many items are formed by bending them to the correct shape at the fabricating stage. This process induces stress into the product, which may be relieved during the hot dip galvanizing operation. This occurs as the molten zinc temperature of around 450°C is at the lower end of the stress relieving temperature for steel. Consequently the stresses used to shape the product may be released giving a resultant change in shape or dimension of the product.

Consider the case of a plate rolled to form part of a circle. During hot dip

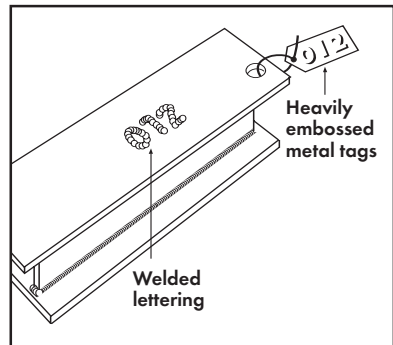

Figure 71.

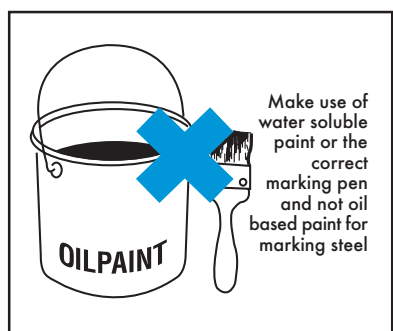

Figure 72.

galvanizing, the release of stress will cause the radius of the circle to increase, and so the final fabricated circle pieces may not meet up (*figure 73*).

These difficulties can be overcome by installing temporary braces across the section to ensure that the object retains its desired shape (*figure 75*). The braces would be either welded or bolted in position, with a size proportional to the size and thickness of the plate they are retaining. If bolted, a flat washer may be used as a spacer between the brace and article to be hot dip galvanized (*figure 74*). The smaller the spacer the smaller the final repair area.

The braces should be located at least at quarter points of the structure. Similar results can be obtained with bent troughs, angle frames or with channels.

It will be necessary to repair the area where the braces have been removed using an approved repair material.

#### Welding or Fabrication Induced Stress

It has been said that the internal stresses due to welding play the greatest part in creating distortion (*figure 76*). Because the steel is heated to 450°C during galvanizing, the stresses introduced by welding are released and this may occasionally give rise to distortion. Welding, however, plays an essential part in creating the fabrications which are to be hot dip galvanized. It is therefore important to understand how these forces are generated and to minimise them during the fabrication to obtain a satisfactory product after hot dip galvanizing.

Fortunately, by following a few simple rules it is possible to get much improved results. These basic rules are:

- Avoid overwelding, welds should be no larger than is essential for the structural integrity of the fabrication.
- Welding should be as symmetrical as possible in order to ensure the stresses are balanced. This can be done by placing welds near the neutral axis or by balancing them around this axis.
- Use a well planned, balanced welding sequence. With large structures extra care should be taken that stresses are minimised by preparing and working to a welding plan.

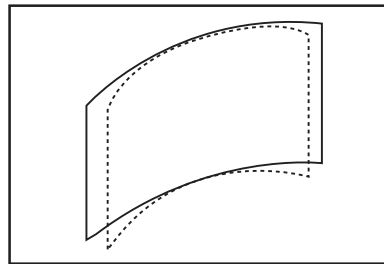

Figure 73.

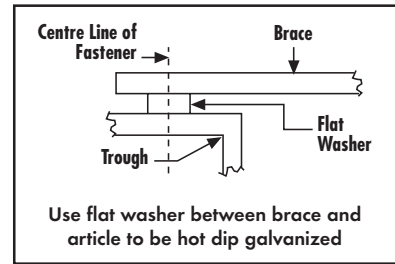

Figure 74.

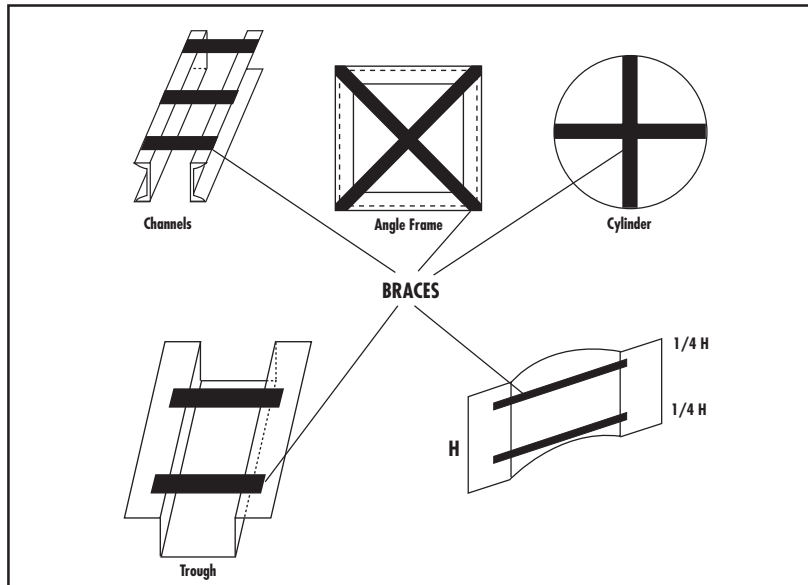

Figure 75.

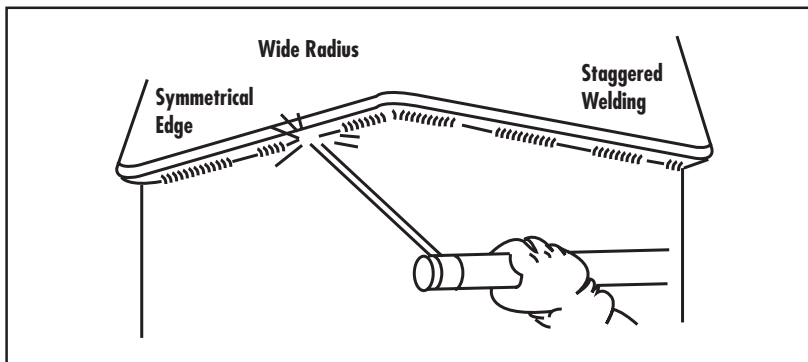

Figure 76.

- Weld seams which significantly reinforce the structural strength should as far as possible be welded last so that do not hinder the contraction of other welds.
  - Use as few weld passes as possible and reduce the welding time to control the heat input.
  - Make weld shrinkage forces work in the desired direction or balance shrinkage forces with opposing forces.
  - Use backstep welding or staggered welding to minimise stresses.
- If a steel fabrication distorts either after welding and before or after hot dip galvanizing due to these stresses, it is possible to restraighten the item. Best results are obtained by hot straightening either before or after hot dip galvanizing. Preference should be given to hot straightening before as the time required is less and the possibility of damage to the zinc

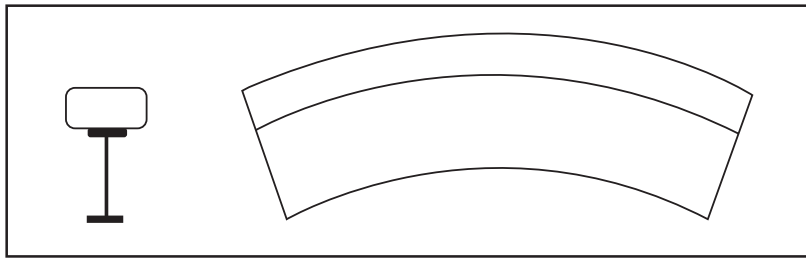

Figure 77.

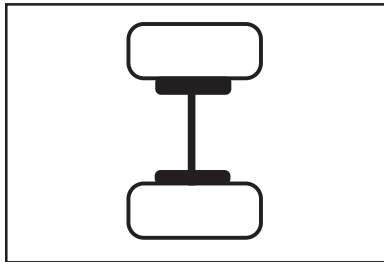

Figure 78.

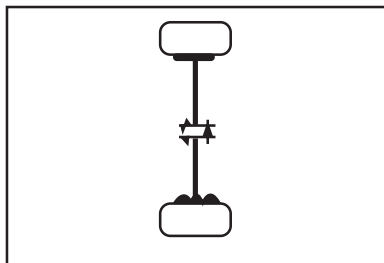

Figure 79.

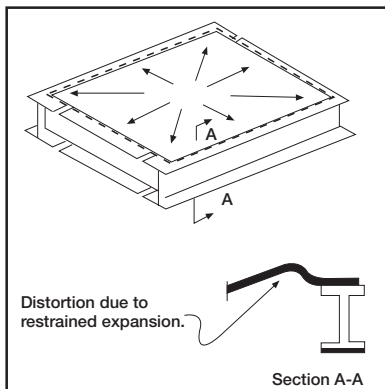

Figure 80.

coating is avoided. Tests confirm that hot straightened components which were within tolerance before hot dip galvanizing do not distort again during the galvanizing process as the stresses have already been relieved.

#### Fabrications that Lack Symmetry

When fabrications are substantially symmetrical in both the horizontal and vertical planes, they have a much lower potential to distort at galvanizing temperatures. Under these conditions, the expansion forces are balanced and the product does not suffer any

distortion. This condition exists with tubes, I-beams, RHS and other similar sections. When these sections are combined in a fabrication, it is possible to remove this symmetry.

Consider the case where a piece of thin walled RHS is welded to the top of an I-beam section. In this situation, the geometric shape is no longer symmetrical, even though the two individual components are.

The thinner walled tube will reach the galvanizing temperature sooner than the thicker flange at the bottom. As a result, the RHS will expand faster than the bottom flange, causing the section to experience an upwards bow (figure 77).

Sections which are not symmetrical, such as Channels and Angles will experience similar problems because of their inbuilt asymmetry. In the case of channels, the section will bow with the toes pointing outwards.

There are three recommended ways to overcome this type of problem.

- Redesign the fabrication to make the design symmetrical. This will enable the forces to balance each other and prevent distortion (figure 78).
- Fabricate and galvanize the individual components as separate pieces, then weld them together after hot dip galvanizing. The welds can be touched up with a suitable galvanizing repair material.
- When multiple pieces are available they can be hot dip galvanized back to back by using bolts with pipe spacers to separate the pieces. The assembly would be separated after cooling completely and the spacer contact area repaired with a suitable galvanizing repair material (figure 79).

#### Using Thick and Thin Material in an Assembly

When thin material is heated during galvanizing, it expands faster than any

thick material heated at the same time. This is because the thinner material takes less time to be fully heated to the galvanizing temperature. The thinner material will therefore distort if its expansion is restrained by thicker material.

Consider the common case where a thin steel sheet is welded to the frame of a trailer to form a tray. This sheet is generally securely attached by welds around its perimeter. If, for example, the sheet is only half as thick as the material used in the frame, it quickly reaches the galvanizing temperature of around 450°C and so has reached the point where maximum expansion will occur.

The frame being made of thicker material will not yet have reached the same temperature and so will not have expanded as much as the thinner sheet. Because of the restraints from the welds around the perimeter, the sheet cannot push its growth outwards at the edges, and so the increase in size causes buckles to occur in the sheet surface (figure 80).

There are two recommended methods of overcoming this problem:

- Hot dip galvanize the sheet and frame separately and then join them after galvanizing. This may be done using mechanical fasteners such as screws or bolts. If welding is used then the welds will need to be touched up with galvanizing repair material.
- Use the same thickness of material for both the frame and the sheet.

In some cases this buckling of the surface may be acceptable, as the material is fully protected against corrosion, however once this type of distortion occurs, it cannot be readily corrected after galvanizing.

#### Hot Dip Galvanizing Oversize Objects

When a fabrication is so large that the galvanizer cannot fit into the bath, a process of either double-dipping or progressive galvanizing is used.

These processes increase the potential for distortion as they introduce uneven heating into the object. The area immersed in the bath is raised to the full galvanizing temperature and therefore expands more than the portion remaining outside of the kettle. This is more pronounced

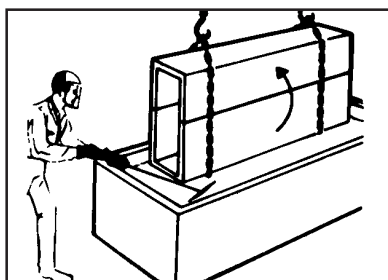

Double-end dipping for excess depth.

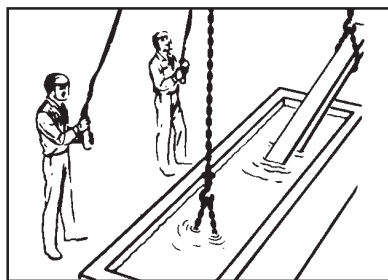

Double-end dipping for excess length.

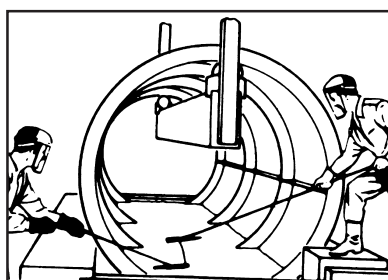

Progressive dipping.

during the first dip when the object is raised from room temperature. It is the differential heating and the resulting difference in expansion that may cause the product to distort. Dipping the second part of the fabrication will not remove any distortion that has already occurred.

This problem will be aggravated if vent and drain holes are undersized as this will require longer galvanizing times while the object fills with zinc and drains while removing. This increased time exaggerates the differential expansion along the steel and hence the possibility of distortion.

These problems can be overcome or reduced by:

- Designing the product in modules which can be totally immersed in a single dip.
- Ensuring that vent and drain holes are adequately sized to enable rapid immersion and withdrawal of the object.
- Allowing for linear expansion in the design so that any distortion is plastic and not constrained by cross bracing.
- Utilise the longest bath available for the galvanizing.

These problems are rarely experienced in simple pipes, poles or thin spiral sections because of their symmetry and simple design.

#### Long Thin Objects

Long thin objects include poles, tubes and larger RHS sections. Generally these objects will not distort due to their symmetrical nature, however if they are lifted at both ends, they may take on a characteristically bowed shape following the galvanizing process.

This bowing is caused when the steel is heated to the galvanizing temperature of 450°C. When withdrawing from the galvanizing kettle, the product's own weight may exceed the yield strength of the steel at this temperature, causing the object to bow. This bowing becomes permanent as the steel cools.

If the product has not been designed with sufficiently large vent and drain holes, the problem can be aggravated by additional zinc being trapped inside the object when it is lifted. Further problems are created by this as the time taken for the zinc to drain allows the deformation of the steel to continue for a longer period and the bowing to become worse.

There are two recommended ways to reduce this problem:

- Lifting lugs or holes should be provided at the quarter points of

these products so that they do not need to be lifted at the ends.

- Vent and drain holes should be placed and sized to maximise the rate of drainage and minimise the retention of zinc inside the section.

Information on correct vent and drain hole sizing is available in the publication "Design for Hot Dip Galvanizing" freely available from your galvanizer.

### 9.5 PACKAGING AND TRANSPORTING OF HOT DIP GALVANIZED STEEL

Even though the hot dip galvanized coating is capable of withstanding fairly rough treatment it should be handled with care during storage and transportation. In the case of long sections, simple packaging and binding into bundles not only prevents handling damage but it often facilitates transportation itself. Packaging and binding should be done in such a way as to avoid the risk of wet storage stain. Spacers should be used to facilitate air circulation between components.

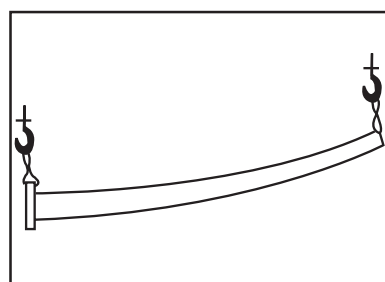

Figure 81.

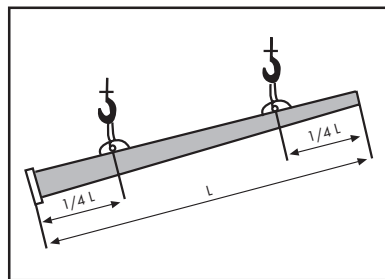

Figure 83.

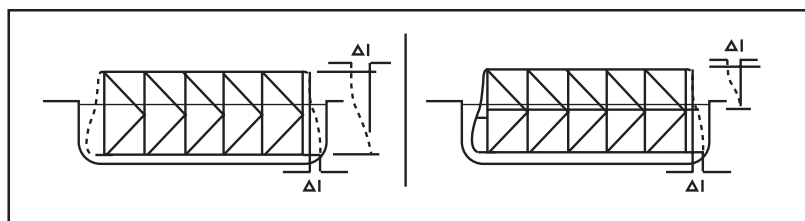

Figure 82.